



BREATHE EASY...Solutions for Clean, Safe Air

MICRO AIR FRP8-3 DUST COLLECTOR

Specifications and Technical Data

TYPICAL APPLICATIONS:

- WELD SMOKE AND FUMES
- GRINDING / POLISHING DUST
- COMPOSITES DUSTS
- ABRASIVE BLAST DUSTS
- SMOKE/ FUMES FROM LASER/PLASMA CUTTING
- PHARMACEUTICAL / FOOD PROCESSES



STANDARD FEATURES:

- REVOLUTIONARY ROTO-PULSE® FILTER CLEANING SYSTEMS
- TRUE LEDGE-LESS CONSTRUCTION FOR OSHA/NFPA COMPLIANCE
- IMPROVED AIR DELIVERY SYSTEM—RATED FOR 5 MILLION CYCLES WITH NO REQUIRED MAINTENANCE
- LARGE CAPACITY DUST DRAWER OR HOPPER
- HINGED DOOR FILTER ACCESS.
- STURDY SUPPORT SYSTEM—DOESN'T REQUIRE CROSS-BRACING IN SIESMIC ZONES 1, 2, & 3, OR IN WIND LOAD RATING ≤115 MPH
- HEAVY DUTY 12 GA. CONSTRUCTION
- RATED FOR INDOOR AND/OR OUTDOOR INSTALLATION
- INDOOR / OURDOOR RATED WITH NEW ROBUST VALVE SYSTEM RATED TO (-40°) - DOES NOT REQUIRE HEATERS IN COLD CLIMATES

OPTIONS:

- HOPPER SETUP WITH LONG LEGS AND BARREL LID KIT. OR LOW PROFILE UNIT WITH DUST DRAWERS
- INLET PLENUM
- SILENCER.
- HEPA AFTERFILTER.
- VARIETY OF CARTRIDGE FILTER OPTIONS.
- 10, 15, 20 OR 30 HP TOP MOUNT / REMOTE MOUNT FANS—OTHER OPTIONS AVAILABLE
- MAGNAHELIC OR PHOTOHELIC GAUGES.
- FULL ELECTRICAL CONTROL PACKAGE
- DROP-OUT MODULES FOR HEAVY PARTICULATE
- INTELLI-TOUCH® ENERGY SAVING CONTROLS
- EXPLOSION VENTS, BACKBLAST DAMPERS, OSHA/NFPA COMBUSTIBLE DUST COMPLIANCE PACKAGE
- SPARK ARRESTORS
- PAINT OPTIONS: BAKED ENAMEL OR EPOXY COAT INSIDE & OUT

HOW IT WORKS:

Contaminated air is pulled into the inlet plenum at the top of the FRP8-3 Cabinet, then travels down through the cartridge

filter section, where the contaminant is filtered and dropped into the hopper or dust drawer. Breathe Easy, clean safe air is exhausted out the bottom of the unit. Cartridge cleaning is accomplished with Micro Air's proprietary Roto-Pulse® cleaning system, where air is pulsed

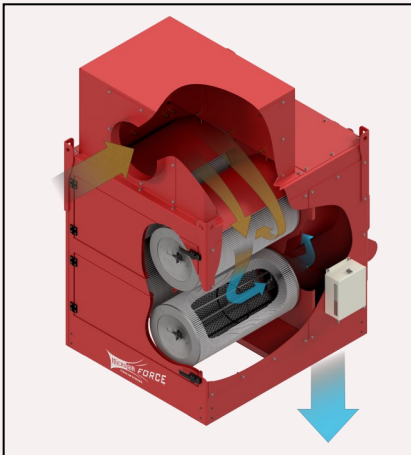

into a specially designed stainless steel, rotating tube, engineered with pre-drilled holes. As the air enters this tube, the force of the pulse causes the tube to rotate incrementally inside the cartridge. While rotating, air

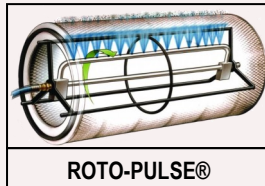

ROTO-PULSE®



FRP8-3 with Intelli-Touch Energy Savings Controls

exits the pre-drilled holes, resulting in air dispersement over the entire surface of the cartridge, providing for an improved cartridge cleaning cycle, compared to competitive backflush cleaning systems .



FRP8-3

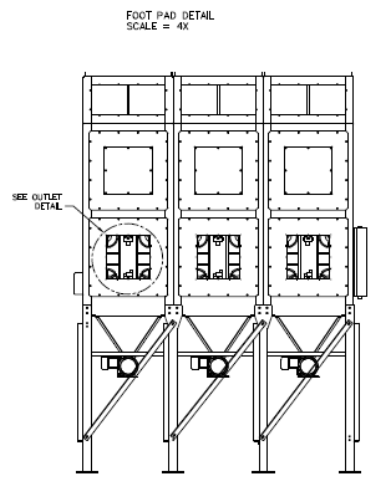
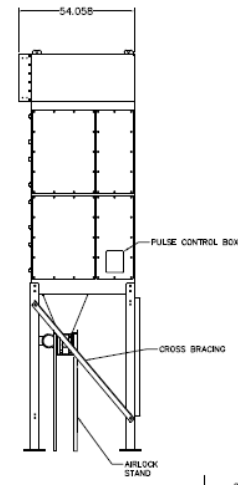
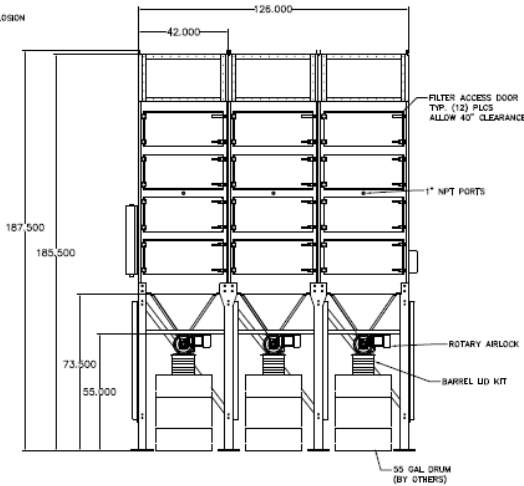
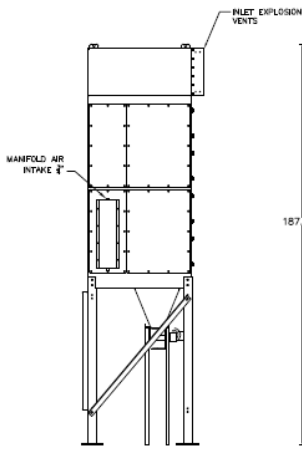
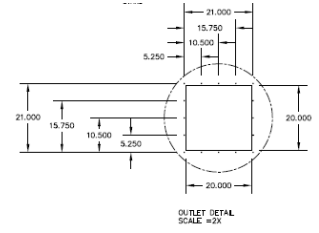
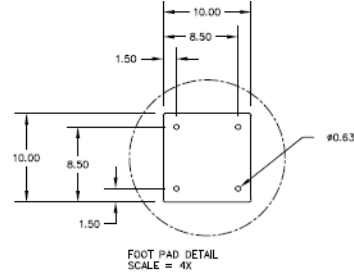
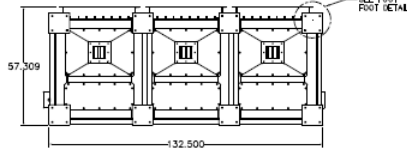
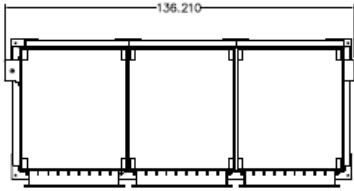

FRP8-3 EQUIPPED WITH REMOTE MOUNT FAN / LONG LEGS / HOPPER / INLET PLENUM / XP VENTS

FRP8-3 SPECIFICATIONS:

OVERALL DIMENSIONS:

178" H X 136" W X 49" D WITH LONG LEGS/HOPPER & INLET PLENUM
 130" H X 136" W X 49" D WITH SHORT LEGS/DUST TRAY & INLET PLENUM

WEIGHT:

- *6,786 LBS APROX. WEIGHT
- *7,086 LBS APROX. SHIPPING WEIGHT
- *WEIGHT VARIES DEPENDING ON OPTIONS SELECTED

CABINET:

HEAVY DUTY 14 GAUGE GALVANEAL STEEL WITH EXTERIOR SURFACES GROUND SMOOTH

FINISH:

INDUSTRIAL GRADE CRIMSON RED, TEXTURED BAKED ENAMEL PAINT IN SIDE AND OUT. OPTIONAL EPOXY COAT INSIDE & OUT AVAILABLE

FILTER ACCESS:

EASY FRONT ACCESS THROUGH HINGED / LATCHED DOORS

FAN-MOTOR/BLOWER

VARIOUS SIZES AVAILABLE IN TOP MOUNT OR REMOTE MOUNT CONFIGURATION, SIZED PER APPLICATION SPECIFICATIONS (10,15, 20, OR 30 HP TOP MOUNT / REMOTE MOUNT FANS AVAILABLE AS STD. OPTION) PREMIUM EFFICIENCY "E", TEFC MOTOR/DIRECT DRIVE BLOWER OTHER CUSTOM OPTIONS AVAILABLE

AIR VOLUME:

DEPENDENT UPON OPTIONS SELECTED—CONSULT FAN CURVES FOR SPECIFICS

FILTER CHANGE INDICATOR:

MAGNEHELIC GAUGE OR PHOTOHELIC GAUGE

FILTRATION:

TWENTY FOUR EA. HIGH EFFICIENCY, 80/20 BLEND, FIRE-RETARDANT CARTRIDGE FILTERS, 250 SF MEDIA PER FILTER, 6,000 SF TOTAL MEDIA
 *MULTIPLE CARTRIDGE MEDIA OPTIONS AVAILABLE

CONTROLS:

FULL ELECTRICAL CONTROLS OPTION / INTELLI-TOUCH CONTROLS

INLET / EXHAUST:

TOP MOUNT OR REMOTE MOUNT INLET PLENUM
 EXHAUST - OUT BOTTOM OF UNIT

MAX CURRENT

- 10 HP, 230/460V—24.6 / 12.3 AMP
- 15HP, 230/460V— 35.0 / 17.5 AMP
- 20 HP, 230/460V—47.0 / 23.5 AMP
- 30 HP, 230/460V—69.0 / 34.5 AMP

NOISE LEVELS:

DEPENDENT UPON OPTIONS SELECTED—CONSULT FACTORY

WIND LOAD RATING:

115 MPH / 160 MPH WITH CROSS-BRACING

CABINET PRESSURE RATING:

+/- 30 INCHES WC

COLLECTION OPTIONS:

HOPPERS WITH 10" DIA COLLAR OR DUST TRAYS

SEISMIC DATA:

S_s=0.551 S₁=0.132

COMPRESSED AIR:

REQUIRES 80—90 PSI CLEAN, DRY AIR & MINIMUM 3/4" AIR LINE

CARTRIDGE CLEANING SYSTEM:

ROTO-PULSE® INCREMENTAL ROTATING TUBE WITH PRE-DRILLED HOLES. AS AIR IS PULSED INTO THE TUBE, IT ROTATES AND AIR EXITS THE PRE-DRILLED HOLES, PROVIDING A HIGHLY EFFICIENT AND TOTAL CLEANING OF THE CARTRIDGE FILTER

OFF-LINE CARTRIDGE CLEANING:

STANDARD EQUIPMENT DESIGNED TO CLEAN FILTERS AFTER UNIT IS TURNED OFF FOR OPTIMAL OFF-LINE CARTRIDGE CLEANING. TIMER CAN BE ADJUSTED BETWEEN 0 AND 17 MINUTES

SPECIFICATIONS SUBJECT TO CHANGE WITHOUT NOTICE