



BREATHE EASY...Solutions for Clean, Safe Air

Ambient T-Style Air Cleaner MXT5000 Specifications and Technical Data

TYPICAL APPLICATIONS:

Ambient Capture of Process Dusts / Mists Generated in Manufacturing processes:

- Welding Smoke & Fumes
- Grinding / Sanding / Polishing
- Metalworking / Composites
- Coolant / Oil Mist & Smoke
- Other Nuisance Dusts Generated in Industrial Processes

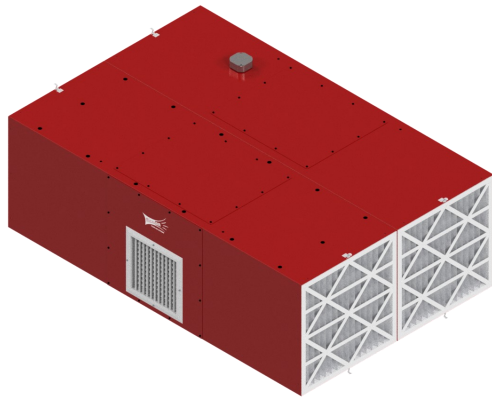

STANDARD FEATURES:

- T-SHAPED DESIGN—DUAL INLET EACH END WITH SINGLE CENTER EXHAUST
- 4" PLEATED PRE-FILTER
- BELT DRIVEN BLOWER
- ADJUSTABLE 4-WAY EXHAUST GRILLE
- QUIET OPERATION 70DBA AT 6' WITH SILENCER
- NO DUCTING REQUIRED
- CFM UP TO 5,400

OPTIONS:

- HORIZONTAL OR VERTICAL CABINET
- 0-5" MAGNEHELIC GAUGE
- MERV 8 SCRIM PRE-FILTER
- ADDITIONAL "FILTER-SAVER" OPTION
- SILENCER
- MULTIPLE MOUNTING OPTIONS AVAILABLE
 - 1) EYEBOLTS
 - 2) C-CHANNEL
 - 3) WALL MOUNT—VERTICAL CONFIGURATION ONLY
 - 4) FLOOR STAND—VERTICAL CONFIGURATION ONLY

HOW IT WORKS:

Contaminated air is drawn in from each end of the collector, and passes through the pleated pre-filters, effectively removing the larger particulate from the air-stream.

Next the air passes through the primary filtration system, 8 pocket bag filters, where the smaller particles of airborne impurities are captured. Clean, pollution-free air is then discharged out the center exhaust grille providing a *Breathe Easy*, safe, work environment.

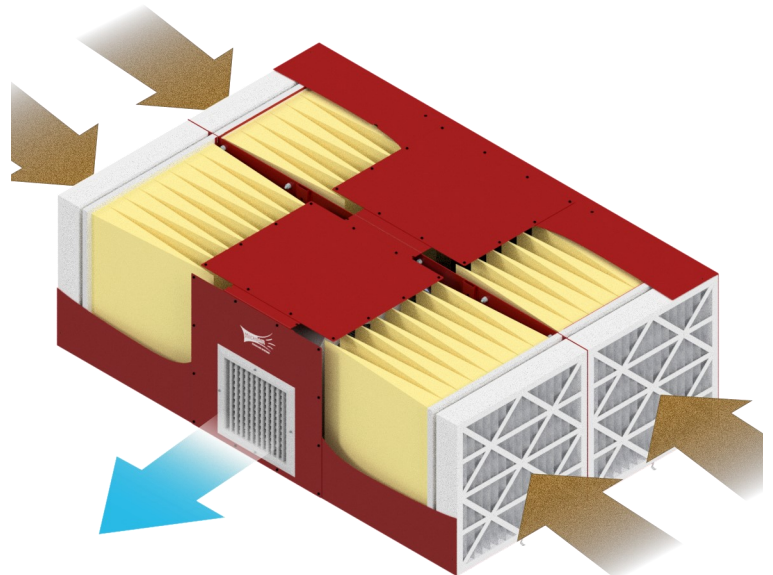

L3037-12/21

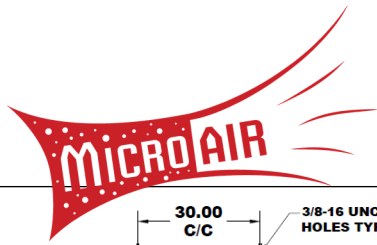

MXT5000

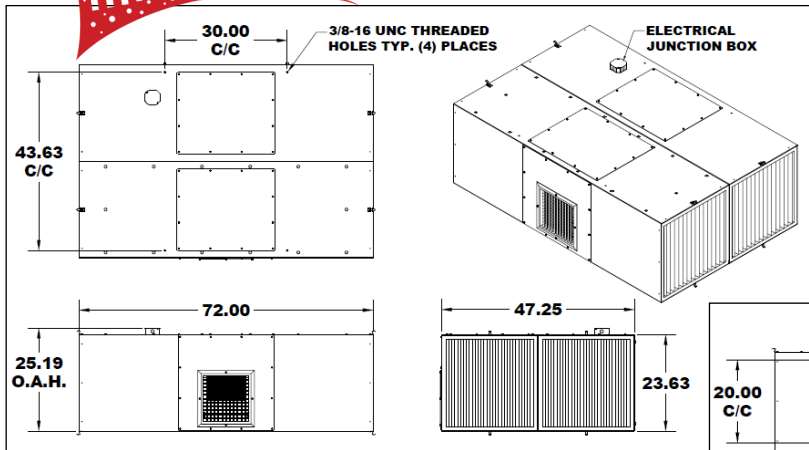

HORIZONTAL STACK CONFIGURATION

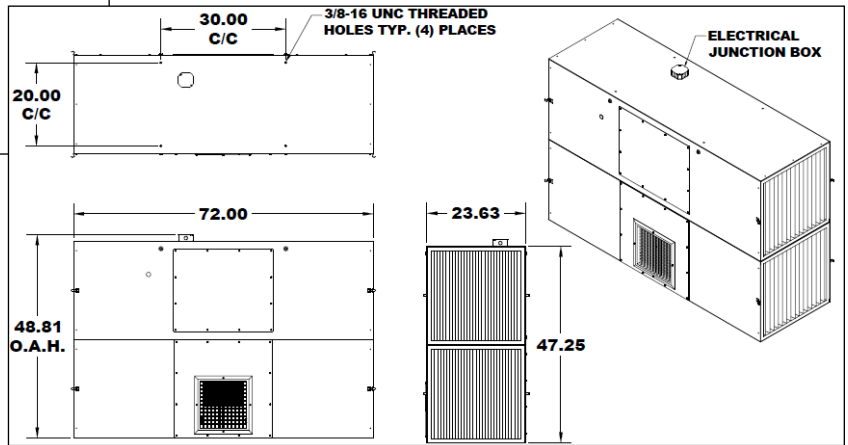

VERTICAL STACK CONFIGURATION

MXT5000 SPECIFICATIONS:

OVERALL DIMENSIONS:

- 25" H X 48" W X 72" L HORIZONTAL CONFIG.
- 49" H X 24" W X 72" L VERTICAL CONFIG.
- 24" H X 72" W X 72" L W / SILENCER—HORIZONTAL CONFIG.
- 49" H X 48" W X 72" L W / SILENCER—VERTICAL CONFIG.

WEIGHT:

- *350 LBS ACTUAL WEIGHT
- *400 LBS SHIPPING WEIGHT
- *WEIGHT VARIES DEPENDING UPON OPTIONS SELECTED

CABINET:

- HEAVY DUTY 17 GA. WELDED GALVANEAL STEEL W/EXTERIOR SURFACES GROUND SMOOTH
- OPTIONS FOR HORIZONTAL OR VERTICAL CONFIGURATION

FINISH:

- INDUSTRIAL GRADE TEXTURED BAKED CRIMSON RED ENAMEL PAINT—INSIDE AND OUT

FILTRATION OPTIONS:

- FOUR EA. MERV 15, 24" X 24" X 22" 95% BAG FILTERS
- FOUR EA. MERV 15, 24" X 24" X 22" 55% BAG FILTERS

PREFILTER

- FOUR EA. 24" X 24" X 4" PLEATED PREFILTER (STD.)
- TWO EA. MERV 8 SCRIM PRE-FILTER (OPTIONAL)

FILTER ACCESS:

- FRONT LOAD, EACH END FOR EASY ACCESS

NOISE LEVEL:

- 78 dBA AT 6' AWAY FROM UNIT
- 70 dBA AT 6' AWAY FROM UNIT WITH SILENCER

INLET / EXHAUST:

- T-STYLE INTAKE AT EACH END / EXHAUST CENTER THROUGH 4 WAY ADJUSTABLE GRILLE

MOTOR:

- 3 HP, 1740 RPM, TEFC

BLOWER:

- 12-9 BELT DRIVEN

INPUT VOLTAGE:

- 208-230/460 VAC, 60 Hz, 3-PHASE

MAX CURRENT:

- 8.9-8.6 / 4.3 AMP

AIR FLOW:

- UP TO 5,400 CFM

FILTER CHANGE INDICATOR (OPTIONAL):

- 0-5" ,MAGNEHELIC GAUGE

MOUNTING OPTIONS:

- EYEBOLTS, C-CHANNEL, WALL MOUNT-(VERTICAL ONLY), FLOOR STAND-(VERTICAL ONLY)

SPECIFICATIONS SUBJECT TO CHANGE WITHOUT NOTICE

L3037-12/21