



BREATHE EASY...Solutions for Clean, Safe Air

MICRO AIR FRP8 DUST COLLECTOR

Specifications and Technical Data



TYPICAL APPLICATIONS:

- WELD SMOKE AND FUMES
- GRINDING / POLISHING DUST
- COMPOSITES DUSTS
- ABRASIVE BLAST DUSTS
- SMOKE/ FUMES FROM LASER/PLASMA CUTTING
- PHARMACEUTICAL / FOOD PROCESSES

STANDARD FEATURES:

- REVOLUTIONARY ROTO-PULSE® FILTER CLEANING SYSTEMS
- TRUE LEDGE-LESS CONSTRUCTION FOR OSHA/NFPA COMPLIANCE
- IMPROVED AIR DELIVERY SYSTEM—RATED FOR 5 MILLION CYCLES WITH NO REQUIRED MAINTENANCE
- LARGE CAPACITY DUST DRAWER OR HOPPER
- HINGED DOOR FILTER ACCESS
- FULL ELECTRICAL CONTROL PACKAGE—STD.
- STURDY SUPPORT SYSTEM—DOESN'T REQUIRE CROSS-BRACING IN SIESMIC ZONES 1, 2, & 3, OR IN WIND LOAD RATING ≤115 MPH
- HEAVY DUTY 12 GA. CONSTRUCTION
- RATED FOR INDOOR AND/OR OUTDOOR INSTALLATION
- INDOOR / OURDOOR RATED WITH NEW ROBUST VALVE SYSTEM RATED TO (-40°) - DOES NOT REQUIRE HEATERS IN COLD CLIMATES

OPTIONS:

- HOPPER SETUP WITH LONG LEGS AND BARREL LID KIT. OR LOW PROFILE UNIT WITH DUST DRAWERS
- INLET PLENUM
- SILENCER.
- HEPA AFTERFILTER.
- VARIETY OF CARTRIDGE FILTER OPTIONS.
- 5HP, 7 1/2HP OR 10HP PLUG FANS
- 10, 15, 20 OR 30 HP TOP MOUNT / REMOTE MOUNT FANS
- MAGNAHELIC OR PHOTOHELIC GAUGES.
- DROP-OUT MODULES FOR HEAVY PARTICULATE
- INTELLI-TOUCH® ENERGY SAVING CONTROLS
- EXPLOSION VENTS, BACKBLAST DAMPERS, OSHA/NFPA COMBUSTIBLE DUST COMPLIANCE PACKAGE
- SPARK ARRESTORS
- PAINT OPTIONS: BAKED ENAMEL OR EPOXY COAT INSIDE & OUT

HOW IT WORKS:

Contaminated air is pulled into the inlet plenum at the top of the FRP8 Cabinet, then travels down through the cartridge filter section, where the contaminant is filtered and

dropped into the hopper or dust drawer. Breathe Easy, clean safe air is exhausted out the bottom of the unit. Cartridge cleaning is accomplished with Micro Air's proprietary Roto-Pulse® cleaning system, where air is pulsed

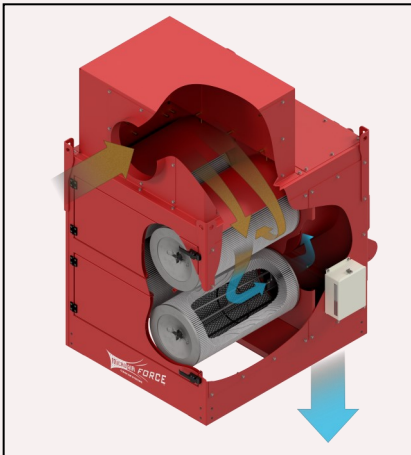

into a specially designed stainless steel, rotating tube, engineered with pre-drilled holes. As the air enters this tube, the force of the pulse causes the tube to rotate incrementally inside the cartridge. While rotating, air

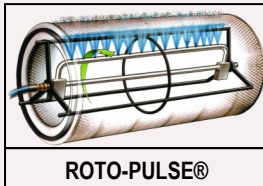

ROTO-PULSE®



FRP8 Ducted to Two Hooded Robotic Weld Operations

exits the pre-drilled holes, resulting in air dispersement over the entire surface of the cartridge, providing for an improved cartridge cleaning cycle, compared to competitive backflush cleaning systems .



FRP8

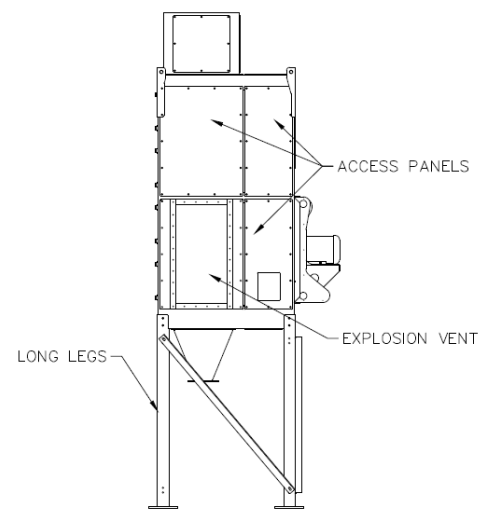
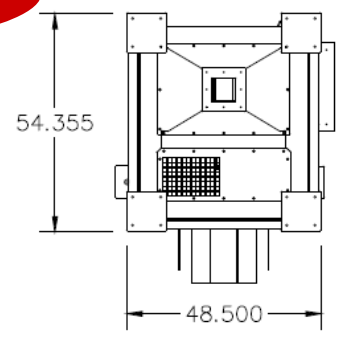
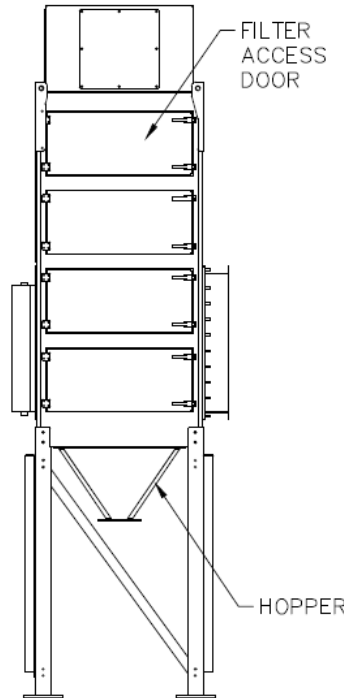
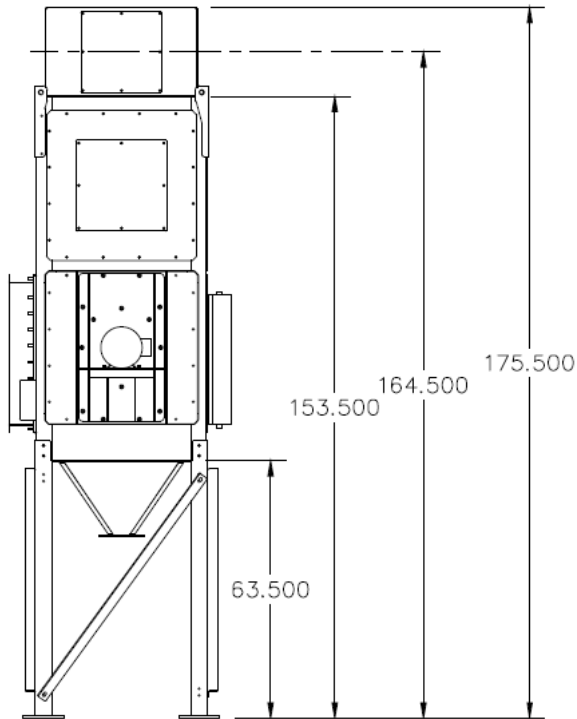

FRP8 EQUIPPED WITH LONG LEGS/HOPPER—INLET PLENUM - EXPLOSION VENT

FRP8 SPECIFICATIONS:

OVERALL DIMENSIONS:

176" H X 54" W X 49" D WITH LONG LEGS/HOPPER & INLET PLENUM
 128" H X 54" W X 49" D WITH SHORT LEGS/DUST TRAY & INLET PLENUM

WEIGHT:

*2,262 LBS ACTUAL WEIGHT
 *2,370 LBS SHIPPING WEIGHT
 *WEIGHT VARIES DEPENDING ON OPTIONS SELECTED

CABINET:

HEAVY DUTY 14 GAUGE GALVANEAL STEEL WITH EXTERIOR SURFACES GROUND SMOOTH

FINISH:

INDUSTRIAL GRADE CRIMSON RED, TEXTURED BAKED ENAMEL PAINT IN SIDE AND OUT. OPTIONAL EPOXY COAT INSIDE & OUT AVAILABLE

FILTER ACCESS:

EASY FRONT ACCESS THROUGH FILTER CAPS

MOTOR

SINGLE SPEED, 5 HP, 3 PHASE, 208-230/460V, 60 HZ, PREMIUM EFFICIENCY, TEFC MOTOR. OPTIONAL 7.5 HP, 10 HP AVAILABLE
 10,15, 20, or 30 HP TOP MOUNT / REMOTE MOUNT FANS AVAILABLE

BLOWER:

DIRECT DRIVE, HIGH STATIC, BACKWARD INCLINED PLUG FAN
 10,15, 20, or 30 HP TOP MOUNT / REMOTE MOUNT FANS AVAILABLE

AIR VOLUME:

DEPENDENT UPON OPTIONS SELECTED—CONSULT FAN CURVES FOR SPECIFICS

FILTER CHANGE INDICATOR:

MAGNEHELIC GAUGE OR PHOTOHELIC GAUGE

FILTRATION:

EIGHT EA. HIGH EFFICIENCY, 80/20 BLEND, FIRE-RETARDANT CARTRIDGE FILTERS, 250 SF MEDIA PER FILTER, 2,000 SF TOTAL MEDIA
 *MULTIPLE CARTRIDGE MEDIA OPTIONS AVAILABLE

CONTROLS:

FULL ELECTRICAL CONTROLS STANDARD

INLET / EXHAUST:

OPTIONAL INLET PLENUM WITH THREE EA. 14" X 14" OPENINGS
 EXHAUST - OUT BOTTOM OF UNIT

MAX CURRENT

5 HP, 230/460V—12.8 / 6.4 AMP
 7.5 HP, 230/460V—19.0 / 9.5 AMP
 10 HP, 230/460V—24.6 / 12.3 AMP
 15HP, 230/460V— 35.0 / 17.5 AMP
 20 HP, 230/460V—47.0 / 23.5 AMP
 30 HP, 230/460V—69.0 / 34.5 AMP

NOISE LEVELS:

DEPENDENT UPON OPTIONS SELECTED—CONSULT FACTORY

WIND LOAD RATING:

115 MPH / 160 MPH WITH CROSS-BRACING

CABINET PRESSURE RATING:

+/- 30 INCHES WC

COLLECTION OPTIONS:

HOPPER WITH 10" DIA COLLAR OR DUST TRAY

SEISMIC DATA:

S_s=0.551 S₁=0.132

COMPRESSED AIR:

REQUIRES 80—90 PSI CLEAN, DRY AIR & MINIMUM 3/4" AIR LINE

CARTRIDGE CLEANING SYSTEM:

ROTO-PULSE® INCREMENTAL ROTATING TUBE WITH PRE-DRILLED HOLES. AS AIR IS PULSED INTO THE TUBE, IT ROTATES AND AIR EXITS THE PRE-DRILLED HOLES, PROVIDING A HIGHLY EFFICIENT AND TOTAL CLEANING OF THE CARTRIDGE FILTER

OFF-LINE CARTRIDGE CLEANING:

STANDARD EQUIPMENT DESIGNED TO CLEAN FILTERS AFTER UNIT IS TURNED OFF FOR OPTIMAL OFF-LINE CARTRIDGE CLEANING. TIMER CAN BE ADJUSTED BETWEEN 0 AND 17 MINUTES

SPECIFICATIONS SUBJECT TO CHANGE WITHOUT NOTICE